



A Maxcess
International
Company

Magnetic Power Systems, Inc.

1626 Manufacturers Drive, Fenton, MO 63026

Tel: 636.343.5550 | Fax: 636.326.0608 | magpowr@magpowr.com

INSTRUCTION MANUAL MODEL DFC-A DANCER-FOLLOWER ARM CONTROL WITH LOW VOLTAGE OUTPUT

1.0 Introduction

The MAGPOWR Model DFC-A is a complete solution for Follower Arm or Dancer control applications. The DFC-A provides a 0 to 10 vdc or 4 to 20 ma output to control a current-to-pressure transducer, or a motor drive in torque mode.

Terminals are provided for the connection of an external 1 mdc current meter. The meter display will indicate output as a percentage of the selected output range (0 to 10 vdc, or 4 to 20 mdc).

The inputs and outputs are referenced to earth ground. The DFC-A operates on 24 vdc input.

2.0 Installation

The DFC-A is intended for installation on a vertical panel using a DIN 35 rail, using the wiring terminals facing down. Figure 1 shows the enclosure dimensions.

All wiring should comply with the essential requirements of the appropriate standard(s) and is the responsibility of the installer.

Route control signal wiring away from AC wiring. Connect shields of shielded cable to the terminals indicated as "SHIELD". Maximum shield length and maximum length of wires outside of the shield is 3 in. (75 mm).

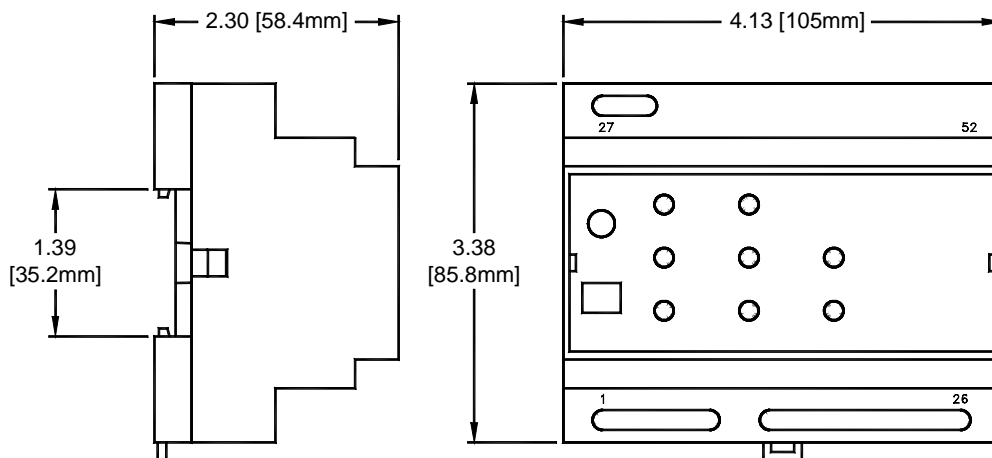

Figure 1
Enclosure Dimensions

3.0 Maintenance

The only maintenance that may be required on the DFC-A is fuse replacement. Replacement of the fuse requires first removing dc power, then opening the enclosure. The enclosure must be re-installed to maintain the IP rating. The enclosure may be opened by inserting a flat blade screwdriver under the retaining tabs in the base (See figure 2).

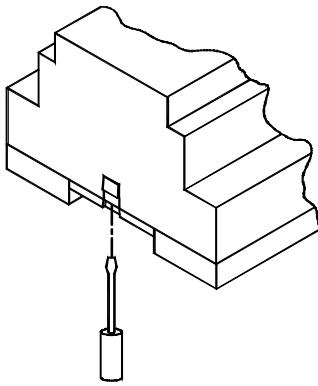

Figure 2
Enclosure Top Removal

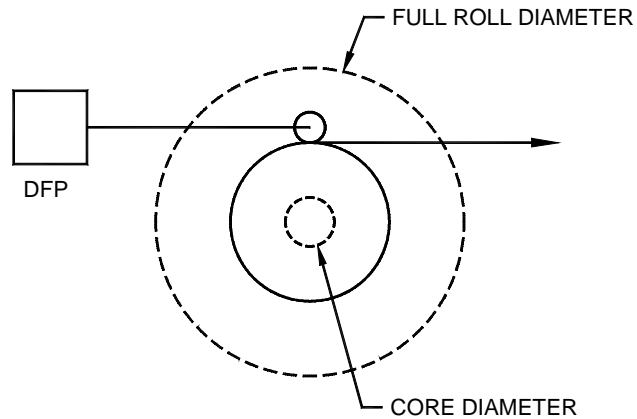

Figure 3
Follower Arm Setup

4.0 Follower Arm Applications

4.1 Electrical Connections

Figure 4 shows the connections that are required for the basic follower arm system. They are:

- 24 vdc power input
- Current-to-Pressure Transducer or a motor drive in torque mode
- DFP or DFP-2 roll diameter sensor
- 10 kohm tension potentiometer

All inputs and outputs have the negative lead referenced to ground.

4.2 Sensor Setup (See Figure 3)

The DFP or DFP-2 position sensor should be at the center of rotation when the follower arm is halfway through its travel. This is an approximate adjustment and is intended to center the sensor position to allow maximum rotation in both directions during operation.

DFP

Adjust the DFP sensor shaft so that its keyway is pointing towards the top cover when the follower arm is half way through its travel.

DFP-2

To find the electrical center point of pot rotation, use a digital multimeter type ohm meter to measure from the white wire (wiper), to the red or black wire. Turn the potentiometer shaft until the meter reads 500 ohm. Install the DFP-2 sensor so the meter reading is 500 ohms when the follower arm is halfway through its travel.

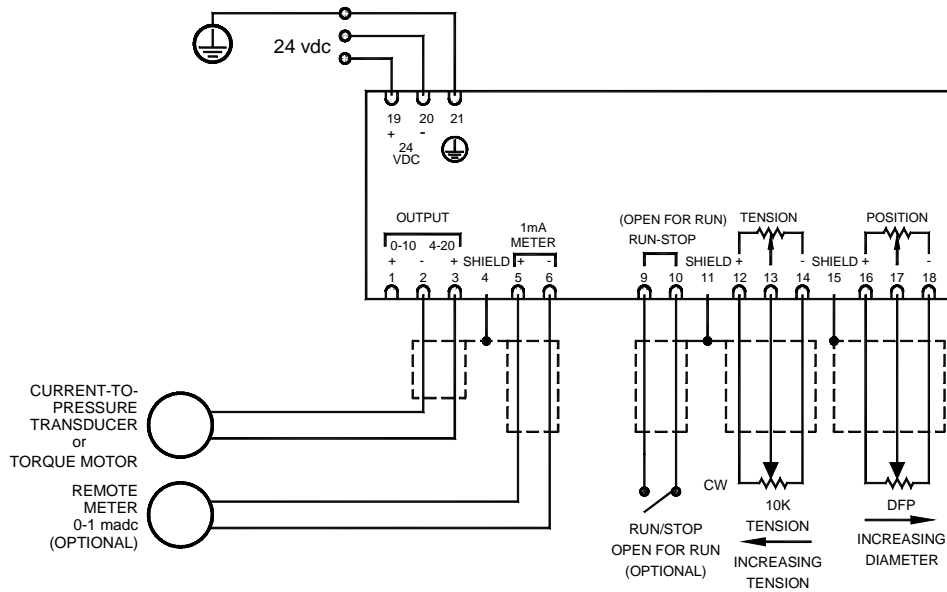

Figure 4
Follower Arm Electrical Connections

4.3 Follower Arm Control Setup

The control adjustments marked with an underline on the label are the only ones needed for follower arm adjustment. Stop time and Stop multiplier apply to all operating modes and are not distinctively marked.

1) Set the following switch and 22-turn potentiometers to the settings given below:

F switch	PD
<u>ZERO</u>	full Counter Clockwise
<u>FULL</u>	full Clockwise
D	full Counter Clockwise
<u>CORE</u>	full Counter Clockwise
<u>STOP TIME</u>	full Counter Clockwise
<u>STOP MULT</u>	full Counter Clockwise

- 2) Set the external TENSION pot full Clockwise.
- 3) Position the follower arm on an empty core.
- 4) Adjust the **CORE** pot to obtain zero on the remote meter.
- 5) Adjust the **ZERO** pot until the meter just starts to increase, and then reverse adjustment direction to just return the meter to zero.
- 6) From published torque versus output curves adjust the **CORE** pot for the desired output at core. (Example: y madc to provide xx psi at core.)
- 7) Place the follower arm at the full roll position, and adjust the **FULL** pot to the desired output at full roll.

Setup is complete, and the DFC-A is ready for operation.

Optional adjustments:

Stop Multiplier and Stop Time. The **STOP MULT** pot can be used to increase the torque while the machine is stopping. The increased torque is applied when the RUN/STOP input is closed (terminals 9 and 10). The length of time the increased torque is applied is adjusted by the **STOP TIME** pot. The STOPPED indicator illuminates when the Stop Time expires.

4.4 Operation

Tension is adjusted using the external 10 kohm tension pot.

Rewind taper can be adjusted using the **FULL** pot. Counter Clockwise rotation of the **FULL** pot will decrease the tension at full roll, thereby increasing the amount of taper.

If the stop multiplier function is used, Clockwise rotation of the **STOP MULT** pot will increase the stopping torque. Clockwise rotation of the **STOP TIME** pot will increase the time that the stopping torque is applied. The **STOP TIME** may be adjusted from 0.2 to 60 seconds.

5.0 Dancer Applications

5.1 Electrical Connections

Figure 5 shows the connections that are required for the basic dancer system. They are:

- 24 vdc power
- Current-To-Pressure Transducer
- DFP or DFP-2 dancer position sensor
- Jumper between terminal 20 & 21

All inputs and outputs have the negative lead referenced to ground.

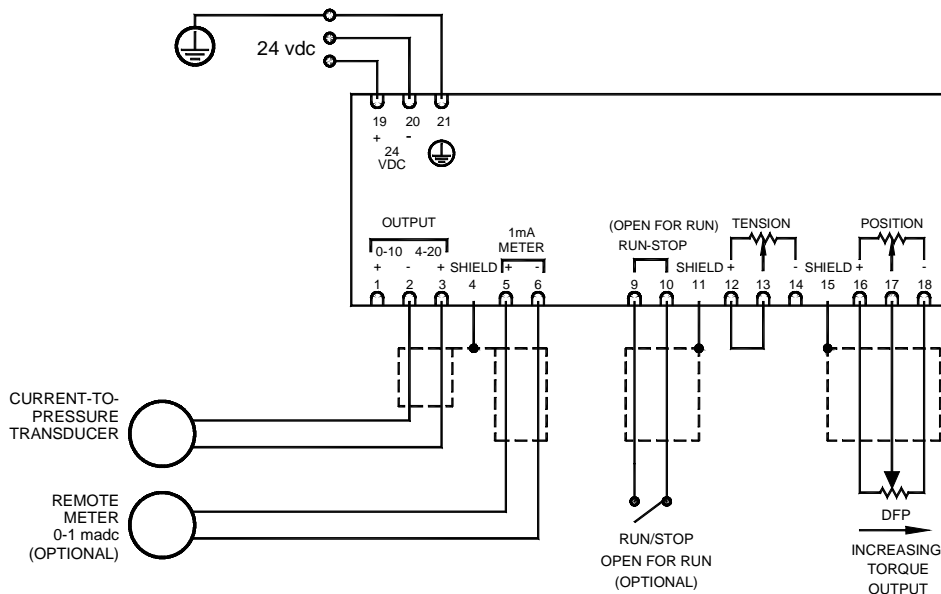

Figure 5
Dancer Electrical Connections

5.2 Sensor Setup

The DFP or DFP-2 position sensor should be at the center of rotation when the dancer is halfway through its travel. This is an approximate adjustment and is intended to center the sensor position to allow maximum rotation in both directions during operation.

DFP

Adjust the DFP sensor shaft so that its keyway is pointing towards the top cover when the dancer is half way through its travel. This is an approximate adjustment, and is intended to center the sensor position to allow maximum rotation in both directions during operation.

DFP-2

To find the electrical center point of pot rotation, use a digital multimeter type ohm meter to measure from the white wire (wiper), to the red or black wire. Turn the potentiometer shaft until the meter reads 500 ohm. Install the DFP-2 sensor so the meter reading is 500 ohms when the follower arm is halfway through its travel.

5.3 Dancer Control Setup and Tuning

The control adjustments marked on the label without an underline or box are the only ones needed for dancer adjustment. Stop Time and Stop Multiplier apply to all operating modes and are not distinctively marked.

1) Set the following switch and 22-turn potentiometers to the settings given below:

<u>F</u> switch	PD
P	full Clockwise
D	mid rotation (approximately 11 turns)
CORE	full Counter Clockwise
STOP TIME	full Counter Clockwise
STOP MULT	full Counter Clockwise

2) With the machine running with web, adjust the **POS1** pot to center the dancer arm.

3) Adjust the **D** pot to minimize dancer arm oscillations. The direction to adjust **D** to minimize oscillations is system dependent.

4) If dancer arm oscillations cannot be eliminated, turn the **P** pot Counter Clockwise and repeat step 3.

Calibration is complete, and the DFC-A is ready for operation.

Optional Adjustments:

Integrator. Many machines run quite successfully after the above adjustments have been made. If the dancer arm moves too much while the roll changes size, the integrator can be turned on to keep the dancer centered.

The control adjustments marked with a box apply to a dancer with integrator.

- 5) Set the **I** pot full Clockwise.
- 6) With the machine stopped, set the **E** switch to **PID** . This turns the integrator on.
- 7) Run the machine near full roll and at a slow speed and use the **POS2** pot to center the dancer. Clockwise rotation of **POS2** moves the dancer up, towards an empty dancer condition.
- 8) Turn the **I** pot Counter Clockwise until the dancer begins to oscillate around the setpoint position. Then, turn the **I** pot Clockwise until the oscillation stops.

The RUN/STOP input must be used if the integrator is on (**E** switch in **PID** position). The RUN/STOP input should be closed (terminals 9 and 10) when the machine starts its deceleration. The DFC-A keeps the integrator on until Stop Time expires. Stop Time may be increased by Clockwise rotation of the **STOP TIME** pot. The STOPPED indicator illuminates when the Stop Time has expired. While the STOPPED indicator is illuminated the DFC-A provides a hold level output that may be adjusted by turning the **HOLD** pot.

Stop Multiplier and Stop Time. Even if integrator mode is not used, the **STOP MULT** pot can be used to increase the torque while the machine is stopping. The increased torque is applied when the RUN/STOP input is closed (terminals 17 and 18). The length of time the increased torque is applied is adjusted by the **STOP TIME** pot. Using the stop multiplier feature in dancer mode could cause the dancer to oscillate while the machine is stopping.

6.0 Optional Dancer Optimization

After tuning of the dancer, the following method will usually optimize the stability and responsiveness of the dancer. The method begins by placing the dancer in PD mode with a roll diameter near core and reducing the gain to a level which the user may consider unacceptable. Gain will subsequently be increased to a more desirable level. If using PID mode, the dancer is placed in PID mode with a roll diameter near full roll and the integrator is reduced to a level which the user may consider unacceptable. Then, the integrator will be increased to a more desirable level. Sometimes, it may be necessary to first make the PD mode adjustment at a larger roll diameter, and then refine the adjustment near core.

Do not switch between PD/ PID while the machine is running since this may result in a large transient jump in the output.

- 1) With a roll diameter near core and the machine stopped, set the **E** switch to **PD** mode.
- 2) Run the machine and adjust the **POS1** pot to center the dancer arm.
- 3) Decrease the **P** pot by rotating Counter Clockwise until the dancer stabilizes. The **POS1** pot may require readjustment several times in order to keep the dancer roll centered.

DEFINITION: In the following steps the user will have to determine if the dancer is overshooting. To do this, move the stable dancer away from its set position by pushing on the dancer, by bumping the unwind/rewind roll, or by some similar means. If the dancer goes past the set position before settling to the set position, it is overshooting. If the dancer goes straight to the stable position without going past it, the dancer is not overshooting.

- 4) Increase the **P** pot by rotating Clockwise in small steps checking for dancer overshoot at each step. Do this until overshoot is obtained.
- 5) Adjust the **D** pot in small steps checking for dancer overshoot at each step. Do this until the overshoot is eliminated. The direction to adjust **D** for no overshoot is system dependent.
- 6) Repeat steps (4) and (5) until the overshoot cannot be eliminated using the **D** pot, or until the **P** pot is full Clockwise.
- 7) Decrease the **P** pot by the amount necessary to eliminate the overshoot.

Adjustment is now complete for the dancer operating in PD mode. The next steps complete the tuning of the dancer operating in PID mode.

- 8) With a roll diameter near full roll and the machine stopped, set the **E** switch to **PID** mode.
- 9) Run the machine and adjust the **POS2** pot to center the dancer roll.
- 10) Decrease the **I** pot by rotating Counter Clockwise in small steps checking for dancer overshoot at each step. Do this until overshoot is obtained.
- 11) Increase the **I** pot by the amount necessary to eliminate the overshoot.

Adjustment is now complete for the dancer operating in PID mode.

7.0 Troubleshooting

7.1 Follower Arm Applications

Symptom	Possible Cause	Solution or Diagnostic
No output.	No DC power.	Verify incoming power is the correct voltage.
	Fuse blown.	Output wires shorted together or shorted to ground.
	Output wires open circuit.	Verify output voltage or current at the receiving device.
	Remote tension adjust potentiometer turned full counter clockwise or not wired properly.	Verify tension pot wiring, turn tension adjust pot full clockwise and follow the calibration procedure in section 4.3. Voltage between terminals 20(+) and 22(-) should be greater than zero and should change as the DFP or DFP-2 is moved through its travel.
	Remote tension potentiometer resistance is less than 10 kohms.	Use a 10 kohm potentiometer for the Remote tension control.

	DFP, DFP-2 position sensor not wired properly or wires shorted.	Verify position sensor is wired properly and follow the calibration procedure in section 4.3. Voltage between terminals 24 and 26 should be 10 vdc. Voltage between terminals 25 and 26 should change as the DFP or DFP-2 is moved through its travel.
	Follower Arm not calibrated.	Follow the calibration procedure in section 4.3.
Output does not increase during stop time.	RUN/STOP switch not connected or not wired properly.	Verify RUN/STOP switch wiring.
	STOP MULTI plier potentiometer not set properly.	Turn STOP MULT potentiometer clockwise to increase the stopping torque.
Remote meter not working.	Incorrect type of meter.	Meter should be a current meter with 1 ma full scale and no more than 500 ohm resistance.
	Meter wires shorted or open.	Disconnect meter wiring at the DFC-A and check for proper meter resistance between the wires.

7.2 Dancer Applications

Symptom	Possible Cause	Solution or Diagnostic
No output.	No DC power.	Verify incoming power is the correct voltage.
	Fuse blown.	Output wires shorted together or shorted to ground.
	Output wires open circuit.	Verify output voltage or current at the receiving device.
	Jumper not installed between 20 and 21.	Install jumper between terminals 20 and 21.
Output full on or full off.	DFP or DFP-2 sensor not wired properly or wires shorted.	Verify DFP or DFP-2 sensor is wired properly and follow the calibration procedure in section 5.3. Voltage between terminals 24 and 26 should be 10 vdc. Voltage between terminals 25 and 26 should change as the DFP or DFP-2 is moved through its travel.

	Dancer not calibrated.	Follow the calibration procedure in section 5.3.
	DFC-A in PID mode and RUN/STOP switch is not wired properly.	Verify RUN/STOP switch wiring. PID mode needs a RUN/STOP switch for proper operation.
Output does not increase during stop time.	RUN/STOP switch not connected or not wired properly.	Verify RUN/STOP switch wiring.
	STOP MULTI plier potentiometer not set properly.	Turn STOP MULT potentiometer clockwise to increase the stopping torque.
Dancer arm hunting during stopping.	STOP MULTI plier is being used.	Turn STOP MULT potentiometer counter clockwise to decrease the hunting during stopping.
Remote meter not working.	Incorrect type of meter.	Meter should be a current meter with 1 ma full scale and no more than 500 ohm resistance.
	Meter wires shorted or open.	Disconnect meter wiring at the DFC-A and check for proper meter resistance between the wires.

8.0 Specifications

Supply Voltage:	24 vdc, +/- 10%, 0.08 amp maximum
Fuse: F1	2.0 amp, Littelfuse Part No. 216.002, or Wickmann Part No. 19194-057-FS
Enclosure:	IP20
Climatic Class:	3K3 (EN60721)
Temperature Range:	
Operating:	0° C to 50° C
Storage:	-30° C to 80° C
Relative Humidity:	5% to 85%
Pollution Degree:	2 (IEC664-1)
Altitude:	0 to 2000 m
Compatible Residual Current	
Device Types:	A or B (IEC755)
Worst Case Fault Current:	2.0 amp dc
Inputs:	
Signal:	DFP or DFP-2 Potentiometer: 1 to 10 kohm, ¼ watt minimum Tension Potentiometer: 10 kohm minimum, ¼ watt minimum
RUN/STOP:	Contact closure, 30 ohm maximum, 0.2 vdc maximum
Outputs:	
Clutch / Brake: Voltage:	0 to 10 vdc, 1 mADC maximum
Current:	4 to 20 mADC, 400 ohm maximum
Regulation:	< 1% of range
Meter Signal:	0 to 1 mADC, +/-2% into 500 ohm maximum
DFP or DFP-2 Reference Voltage:	10v +/-2%, 10 mADC maximum