



Magnetic Power Systems, Inc.

1626 Manufacturers Drive. Fenton, MO 63026

Tel: 636.343.5550 | Fax: 636.326.0608 | magpowr@magpowr.com

## INSTRUCTION MANUAL LOCKING BRACKET MODEL LB

### Theory of Operation

The locking bracket is used to convert a Model C style clutch, into a Model C-\_B brake by locking the output shaft to prevent its rotation.

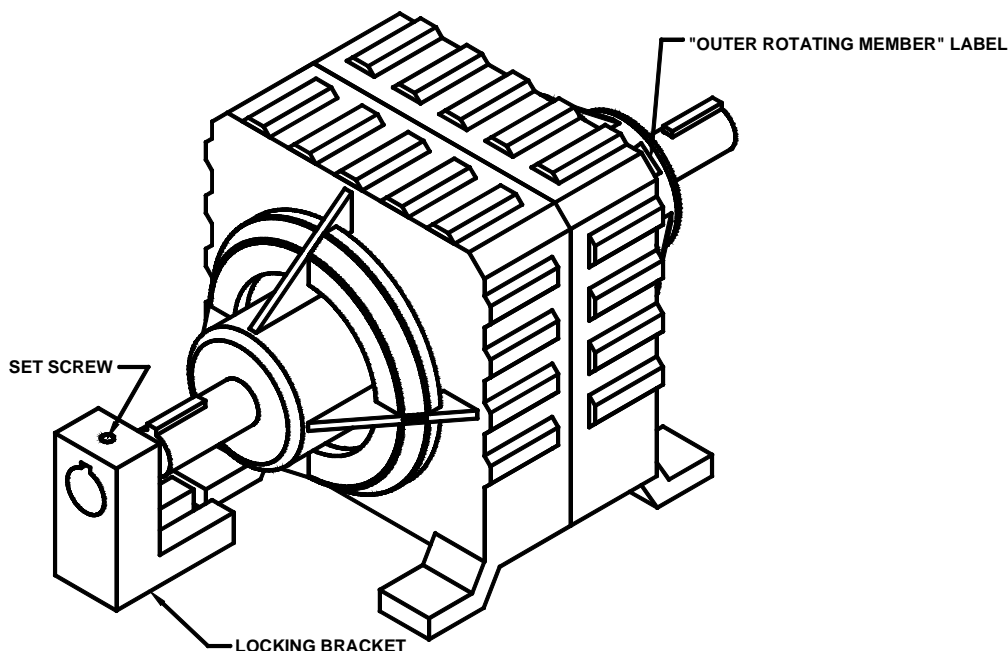

### Installation

1. Insert the locking bracket over the output shaft as shown above. The output shaft is opposite the "outer rotating member end" label. To identify the output shaft on a clutch that has not been connected to any machinery, rotate each shaft by hand while holding the other shaft stationary. The shaft that does not cause the fins to rotate is the output shaft. Attach the locking bracket to the output shaft.
2. Verify that the slot in the locking bracket engages the rib on the clutch casting.
3. Tighten the set screw to secure the locking bracket.

Model	LB-1	LB-3	LB-10	LB-50	LB-100
Setscrew, in.	#10-32	#10-32	#10-32	#1/4-20	#3/8-16
Hexwrench	3/32 in.	3/32 in.	3/32 in.	1/8 in.	3/16 in.
Brake Model No. with LB installed	C-1B	C-3B	C-10B	C-50B	C-100B