

# INSTRUCTION MANUAL

## MISTR™

### ULTRASONIC TENSION CONTROL AND RANGER

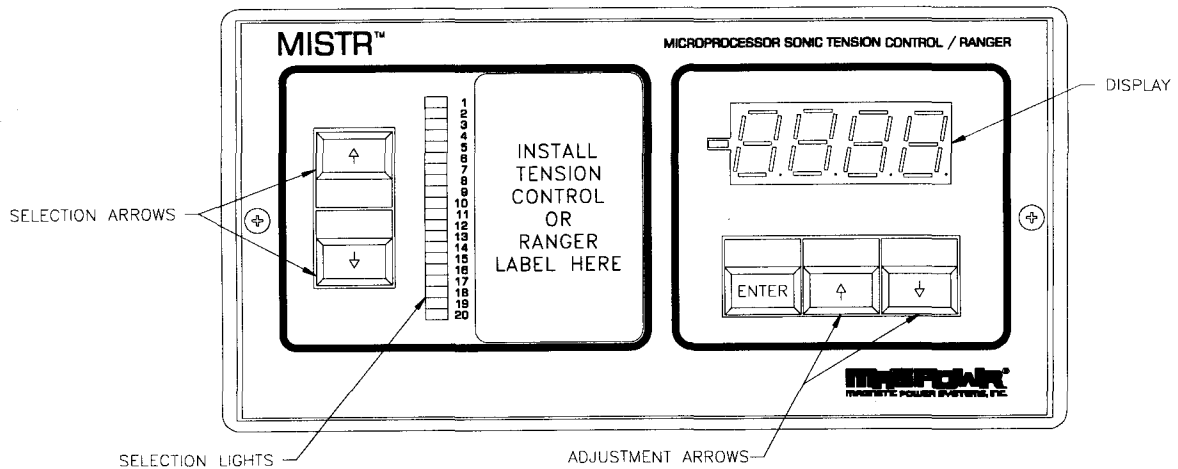

TENSION CONTROL	
1	% OUTPUT
2	TENSION SETPOINT %
3	PRESENT DIAMETER
4	TENSION OFF=0 ON=1
5	% TAPER
6	SETUP NUMBER
7	CORE DIAMETER
8	FULL ROLL DIAMETER
9	DISTANCE TO AXIS
10	STOP TIME
11	STOP MULTIPLIER
12	ECHO REJECT DISTANCE
13	SECURITY OFF=0 ON=1
14	COPY FROM--TO
15	MIN DIAMETER DETECT
16	MAX DIAMETER DETECT
17	MANUAL % OUTPUT
18	MANUAL MODE
19	STOPPED
20	TENSION ON

RANGER	
1	DISTANCE
2	PERCENT OUTPUT
3	POSITION
4	DISTANCE FOR MAX OUTPUT
5	DISTANCE FOR MIN OUTPUT
6	SETUP NUMBER
7	SECURITY OFF=0 ON=1
8	COPY FROM--TO
9	ALARM 1 ON DISTANCE
10	ALARM 1 OFF DISTANCE
11	ALARM 2 ON DISTANCE
12	ALARM 2 OFF DISTANCE
13	ECHO REJECT DISTANCE
14	DISTANCE FOR DISPLAY=0
15	READOUT MULTIPLIER
16	CLOSED LOOP GAIN
17	INTEGRATOR TIME
18	P-I=0 P ONLY=1
19	STOP TIME
20	STOPPED

## TABLE OF CONTENTS

SECTION	Page	SECTION	Page
1. Introduction	2	9. Description of Ranger & Free Loop Control Items	8
2. Unwind or Rewind Tension Control Installation	2	10. Program Adjustment Mode	10
3. Unwind Setup	2	11. Setting Jumpers	11
4. Rewind Setup	4	12. Remote Control Wiring	12
5. Description of Tension Control Items	4	13. Installation of 24/90 Volt Power Amplifier	13
6. Ranger / Free Loop Installation	6	14. Error Codes	15
7. Ranger Setup	7	15. Reset Procedure	15
8. Free Loop Setup & Tuning	7	16. Wiring Diagram	16

## 1. INTRODUCTION

The MAGPOWR MISTR, Ultrasonic Tension Control and Ranger, is both a non-contact web tension control system and a ranging device with proportional outputs and solid state relay outputs. The MISTR features ease of setup and use, and offers a wide choice of function and outputs. When used as a Tension Control with MAGPOWR clutches and brakes, constant tension or taper tension can be accomplished. When used as a Free Loop or Ranger the system provides proportional control of a process, and/or will function as two "micro switches" as you choose. See fig. 1 & 2. The range of this system is 6 to 100 inches (152 to 2540 mm). An ultrasonic sensor Model US-1 is required for use with this product.

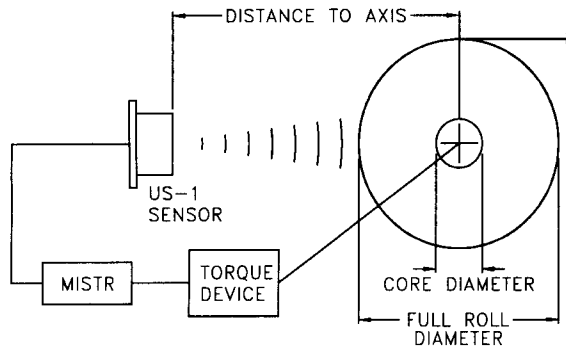

Tension Control  
Fig. 1

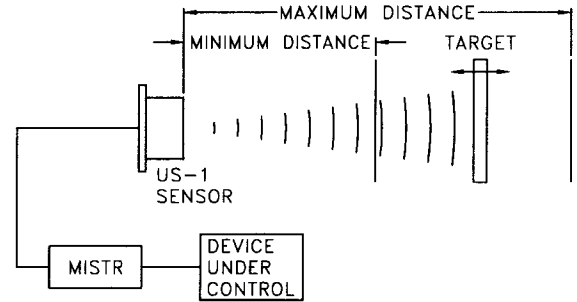

Ranger or Free Loop  
Fig. 2

PACKING LIST	1	MISTR Control
	1	Label sheet with two labels marked "TENSION CONTROL" and "RANGER"
	2	Securing bars
	2	Securing screws

## 2. UNWIND OR REWIND TENSION CONTROL INSTALLATION

The MISTR is shipped from the factory ready to be used as an Unwind tension control. If you are controlling a magnetic particle clutch or brake, you will also need a power amplifier 3B138-1RPL. If you are controlling a pneumatic brake, you will need a current-to-pressure transducer, Model IPT or IP80. For a Ranger or Free Loop application, see section 6.

## 3. UNWIND SETUP

STEP 1 - Remove the MISTR and the set of label inserts from the shipping carton.

STEP 2 - Peel the label that has "TENSION CONTROL" at the top from the label sheet and carefully apply it to the vacant label area on the front of the MISTR. When correctly installed, the text "% OUTPUT" on the label insert should be aligned with the number "1" in the column of numbers.

STEP 3 - If using a magnetic particle brake, see section 13 to install the 3B138-1 power amplifier. If using a pneumatic brake, you must have a current-to-pressure transducer and change jumpers on the main board of the MISTR, see section 11 SETTING JUMPERS

STEP 4 - Mount the MISTR in a protected area with a temperature range of 32-104° F (0-40° C). For front panel mounting, use the securing bars and screws (included) as shown below in Figure 3. For the MISTRP, use suitable hardware to mount to the back panel. See Figure 4.

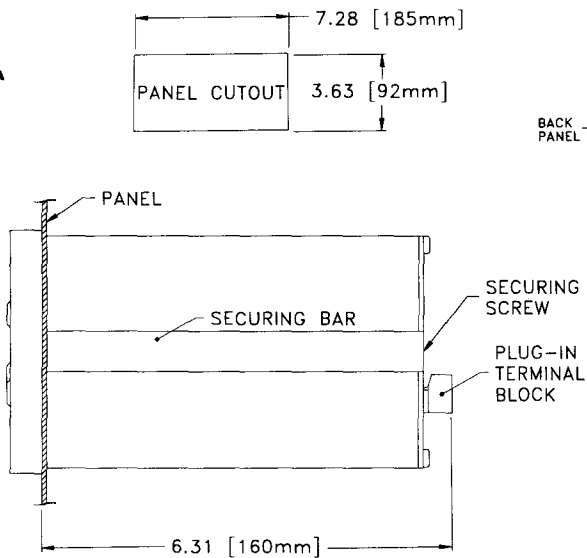

Front Panel Mount  
Fig. 3

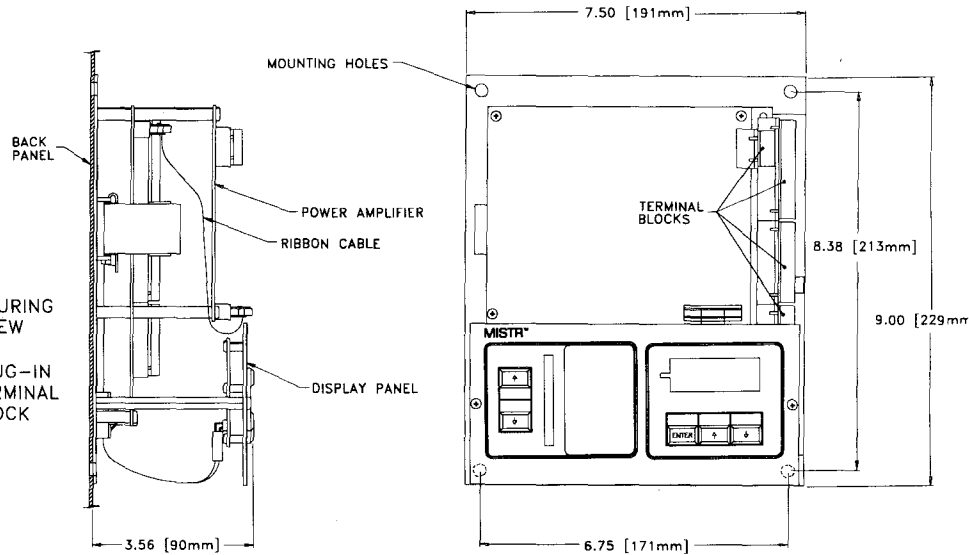

Rear Panel Mount  
Fig. 4

- STEP 5 - Connect the electric brake or clutch by suitable wiring to terminals 101 and 102, otherwise connect to terminals 26 and 27 for control signal outputs. See wiring diagram, Fig.12.
- STEP 6 - Mount the ultrasonic sensor (US-1) a minimum of 6 inches (150mm) and a maximum of 100 inches (2500mm) from the target. The standard cable supplied with the US-1 is 25 feet long (7.6m).
- STEP 7 - Connect the US-1 cable wiring to terminals 4 thru 7.
- STEP 8 - Connect the system run/stop switch to terminals 8 and 9. Terminals 8 and 9 are to be connected for stopping and disconnected for running.
- STEP 9 - Connect the power wiring to terminals 1, 2, and 3. The 115/230 switch on the back panel is factory set to 230. If the power source is 115 vac, change the switch so that 115 is showing. NOTE: For 100/200 volt operation see SETTING JUMPERS, section 11.
- STEP 10 - Apply power. When power is applied, the %OUTPUT selection light will turn on and the display will show the present output level in percent of full output.
- STEP 11 - To aid in aligning the sensor, press both selection arrows for two seconds. Adjust the position and angle of the sensor to obtain a number in the display. (The display will be blank if alignment is poor, and will show the distance to the target when the sensor is aligned.) Press both selection arrows again to return to operating mode.
- STEP 12 - Set core, full roll, and distance to axis by selecting each from the front panel list and using the adjustment arrows to set the distance.
- STEP 13 - Start the machine and set TENSION SETPOINT % to the desired level.

#### 4. **REWIND SETUP**

Caution: Disconnect power to rewind motor controller.

STEPS 1 - 12 Install as per UNWIND SETUP section 3, Steps 1 through 12.

STEP 13 - Press both selection arrows for 2 seconds. Lowest two lights will blink, indicating PROGRAM ADJUSTMENT MODE. Use selection arrows to move selection light to position #2. Use adjustment arrows to select "2" for rewind. Press both selection arrows to return to operating mode. Changes allowed only while the system is stopped.

STEP 14 - Apply power to the rewind motor controller and /or clutch, start the machine and set TENSION SETPOINT % to the desired level.

#### 5. **DESCRIPTION OF TENSION CONTROL ITEMS**

This section applies to both UNWIND and REWIND operation. To look at one of the items listed, use the selection arrows to turn on the light next to its number. To change the item, use the adjustment arrows.

[1] **% OUTPUT** Shows the present level of output being applied to the clutch, brake, or drive and can be between 0 and 100. The level of voltage or current at terminals 26 (-) and 27 (+) is indicated by this value and by the range set by jumper JP1. (See SETTING JUMPERS.) Pressing either adjustment arrow changes the output. The % OUTPUT can be changed until TENSION SETPOINT % reaches 0 or 100 percent. When this happens the display changes to TENSION SETPOINT % to show that it has reached its limit. In manual mode, % OUTPUT is the same as the value set in MANUAL % OUTPUT.

[2] **TENSION SETPOINT %** The display shows the tension level set by the user. The factory setting is 0.0%. Use the adjustment arrows to change the value.

[3] **PRESENT DIAMETER** The roll diameter is displayed. DISTANCE TO AXIS must be entered before a correct display will occur.

[4] **TENSION OFF=0 ON=1** When this light is on, the display shows whether tension is on or off. "0" is displayed if tension is off, "1" is displayed if tension is on. To turn tension on or off, press the adjustment arrows. Tension can also be turned on and off remotely, see REMOTE CONTROL WIRING, section 12.

[5] **% TAPER** Taper is associated with a rewind tension control. The tension at core is continuously reduced, until at full roll, tension has been reduced by the percentage displayed here. A % TAPER of 0 means that tension is not reduced and full roll tension will be the same as core tension (constant tension).

[6] **SETUP NUMBER** The setup stores all the adjustments for a particular material. The value displayed is the present setup number. There are a total of six setups. To switch to another setup use the adjustment arrows. The display will blink when any number other than the present setup number is displayed. To change to the setup number that is blinking, press and hold ENTER for two seconds until the number stops blinking. Setups can be changed only while the system is stopped.

[7] **CORE DIAMETER** The value is the diameter of the core in inches or mm.

[8] **FULL ROLL DIAMETER** The value is the diameter of the full roll.

[9] **DISTANCE TO AXIS** The value is the distance from the face of the sensor to the axis (center) of the roll.

[10] **STOP TIME** This is the number of seconds from the time the user applies the stop signal until the system is stopped. The stop signal is applied by the user at terminals 8 and 9. After this time, the system output returns to the normal operating value.

[11] **STOP MULTIPLIER** Tension control action is multiplied by this value during STOP TIME. The factory setting is 1.00. Increase the value if tension falls during stop time. Decrease the value if tension rises.

[12] **ECHO REJECT DISTANCE** The MISTR ignores objects that are closer to the sensor than this distance. The minimum distance allowed between the actual target and ECHO REJECT DISTANCE is 2 inches (50 mm).

[13] **SECURITY OFF=0 ON=1** A number can be entered by the user to lock out changes to settings. Use the adjustment arrows to enter a 1 to 4 digit security code number. Then press and hold ENTER for two seconds to turn security on. The display will show a "1". To turn security off, enter the number you used to secure the setup and press ENTER. The display will show a "0". Each setup has its own security code. Security codes are not copied between setups.

[14] **COPY FROM--TO** Copies information between setups. The left adjustment arrow changes the left or "FROM" setup number. The right adjustment arrow changes the right or "TO" setup number. Press and hold ENTER for two seconds to do the copy. Setup 0 contains the original factory settings and can be copied FROM but not TO.

[15] **MIN DIAMETER DETECT** Enter the diameter of the desired minimum diameter detection point. The solid state relay output marked "ALARM 1" at terminals 18 and 19 will close whenever diameter is less than or equal to the display value. NOTE: Hysteresis and delay will change the way the output works slightly. See section 10 PROGRAM ADJUSTMENT MODE.

[16] **MAX DIAMETER DETECT** Enter the diameter of the desired maximum diameter detection point. The solid state relay output ALARM 2 at terminals 20 and 21 will close whenever diameter is greater than or equal to the display value. NOTE: Hysteresis and delay will change the way the output works slightly. See section 10 PROGRAM ADJUSTMENT MODE.

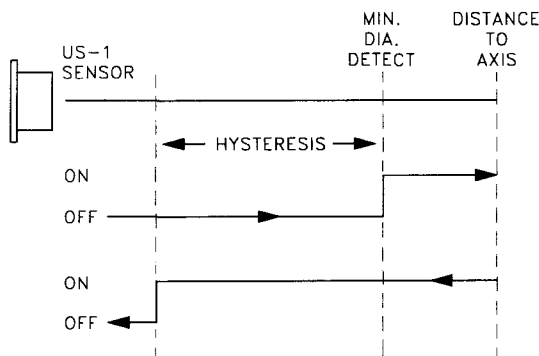

(Unwind Min. Diameter Detect)

Fig. 5

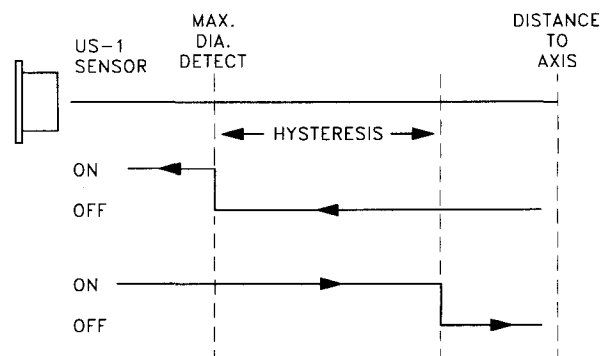

(Rewind Max. Diameter Detect)

Fig. 6

[17] **MANUAL % OUTPUT** In MANUAL mode the control sets the output to this constant value. You can use the adjustment arrows to change this value. Pressing ENTER turns MANUAL MODE off or on.

[18] **MANUAL MODE** Light is on when in manual mode.

[19] **STOPPED** Light is on, and control is in stop mode, when the customer connects terminals 8 and 9 together.

[20] **TENSION ON** Light is on when tension is on.

## 6. **RANGER OR FREE LOOP INSTALLATION**

STEP 1 - Remove the MISTR and the set of label inserts from the shipping carton.

STEP 2 - Peel the label that has "RANGER" at the top from the label sheet and carefully apply it to the vacant label area on the front of the MISTR. When correctly installed, the text "DISTANCE" on the label insert should be aligned with the number "1" in the column of numbers.

STEP 3 - Mount the MISTR in a protected area with a temperature range of 32-104° F (0-40° C). For front panel mounting, use the securing bars and screws (included) as shown in Fig. 3. For the MISTRP, use suitable hardware to mount to the back panel as shown in Fig 4.

STEP 4 - Mount the ultrasonic sensor (US-1) a minimum of 6 inches (150mm) and a maximum of 100 inches (2500mm) from the target. The standard cable supplied with US-1 is 25 feet long (7.6m).

STEP 5 - Connect the US-1 cable wiring to terminal 4 thru 7 as shown in Fig 12.

STEP 6 - Connect electric clutch or brake to terminals 101 and 102, otherwise connect load to terminals 26 and 27.

STEP 7 - Set internal jumpers if needed. See section 11, SETTING JUMPERS.

STEP 8 - Connect remote control wiring if needed. See REMOTE CONTROL WIRING, section 12.

STEP 9 - Connect the power wiring to terminals 1, 2, and 3. The 115/230 switch on the back panel is factory set to 230. If the power source is 115vac, change the switch so the 115 is showing. For 100/200 volt operation see SETTING JUMPERS, section 11.

STEP 10 - Disconnect power from device (i.e. motor, servo drive, etc) being controlled, and apply power to the MISTR. When power is applied, the DISTANCE selection light will turn on.

STEP 11 - To aid in aligning the sensor, press both selection arrows for two seconds. Adjust the position and angle of the sensor to obtain a number in the display. (The display will be blank if alignment is poor, and will show the distance to the target when the sensor is aligned).

STEP 12 - Select RANGER or FREE LOOP operation from PROGRAM ADJUSTMENT MODE, see section 10. Press both selection arrows again to return to operating mode. Changes allowed only while the system is stopped.

## 7. RANGER SETUP

When used as a ranger, the MISTR will give an output which is proportional to distance, and/or a signal at alarm 1 and alarm 2 distances.

STEP 1 - Select DISTANCE FOR MAX OUTPUT, and enter the distance from the US-1 to the desired maximum target location. 25

STEP 2 - Select DISTANCE FOR MIN OUTPUT, and enter the distance from the US-1 to the desired minimum target location. The alarms 1 and 2 can also be programmed to be active at a desired distance. See section 9.

STEP 3 - Select DISTANCE.

STEP 4 - Apply power to the device being controlled. System is now operating.

## 8. FREE LOOP SETUP AND TUNING

The parameters DISTANCE FOR MAX OUTPUT and DISTANCE FOR MIN OUTPUT set the basic gain for the system. These values are chosen so that the free loop will operate between them. DISTANCE FOR MAX OUTPUT is not always a greater distance than DISTANCE FOR MIN OUTPUT. The following rule defines which is greater:

RULE: When the web is moving and the motor or clutch or brake is at maximum output, the free loop will move from the DISTANCE FOR MAX OUTPUT toward DISTANCE FOR MIN OUTPUT.

STEP 1 - Select DISTANCE FOR MAX OUTPUT. Enter the distance from the US-1 to the loop per the above rule.

STEP 2 - Select DISTANCE FOR MIN OUTPUT. Enter the distance from the US-1 to the loop per the above rule.

STEP 3 - Select POSITION. Enter the desired operating position. The normal value is about halfway between DISTANCE FOR MAX OUTPUT and DISTANCE FOR MIN OUTPUT.

STEP 4 - Select and enter the value for <sup>CLOSED</sup>~~FREE~~ LOOP GAIN. The factory setting (1.00) usually provides satisfactory operation.

STEP 5 - Select and enter the value for INTEGRATOR TIME. The factory setting (1.00) usually provides satisfactory operation.

STEP 6 - Select Item #18, (P + I = 0, P ONLY = 1) and enter "1", i.e. "P ONLY" mode.

STEP 7 - Select CLOSED LOOP GAIN. In the following steps it may be necessary to readjust POSITION. The ENTER key can be pressed to quickly switch between CLOSED LOOP GAIN and POSITION.

STEP 8 - With the unwind/rewind near full roll, run the machine with web at a slow speed. Accelerate slowly to ensure that the loop stays within the desired range. If the loop oscillates, press the "↓" key until the oscillation stops.

STEP 9 - Using the "↑" key, increase the CLOSED LOOP GAIN until the loop position just begins to oscillate. Press the "↓" key until the oscillation stops.

STEP 10 - Run the machine with the unwind/rewind near core. (It may be necessary to readjust position.)  
Select Item 18 ( $P + I = 0$ ,  $P \text{ ONLY} = 1$ ) and enter "0" for "P + I" mode.

STEP 11 - Select INTEGRATOR TIME. If the loop oscillates, press the "↑" key until the oscillation stops.

STEP 12 - Press the "↓" key until the loop position just begins to oscillate. Press the "↑" key until the oscillation stops. FREE LOOP TUNING IS COMPLETE

STEP 13 - Select DISTANCE for normal running mode.

## 9. DESCRIPTION OF RANGER AND FREE LOOP CONTROL ITEMS

[1] **DISTANCE** The value is target distance. (with  $\text{DISTANCE FOR DISPLAY} = 0$  and  $\text{READOUT MULTIPLIER} = 1$ )

[2] **% OUTPUT** The number displayed is between "0" and "100" to show the present level of output. The level of voltage or current at terminals 26 and 27 is controlled by this value, and by the range set by jumper JP1. See SETTING JUMPERS section 11.

[3] **POSITION** This is the distance (or position) set point when controlling the amount of web in a free loop type positioning control, (not available for other control modes).

[4] **DISTANCE FOR MAX OUTPUT** The distance at which % OUTPUT will reach 100.

[5] **DISTANCE FOR MIN OUTPUT** The distance at which % OUTPUT will reach 0.

[6] **SETUP NUMBER** The value displayed is the present setup number. There are a total of six setups. To switch to another setup use the adjustment arrows. The display will blink when any number other than the present setup number is displayed. To change to the setup number that is blinking, press and hold ENTER for two seconds until the number stops blinking. Setups can be changed only while the system is stopped.

[7] **SECURITY OFF=0 ON=1** A number can be entered by the customer to lock out changes to settings. Use the adjustment arrows to enter a 1 to 4 digit security code number. Then press and hold ENTER for two seconds to turn security on. The display will show a "1". To turn security off enter the number you used to secure the setup and press ENTER. The display will show a "0". Each setup has its own security code. Security codes are not copied between setups.

[8] **COPY FROM -- TO** Copies information between setups. The left adjustment arrow changes the left or "FROM" setup number. The right adjustment arrow changes the right or "TO" setup number. Press and hold ENTER for two seconds to do the copy. Setup 0 contains the original factory settings and can be copied FROM but not TO.



- [9] ALARM 1 ON DISTANCE
- [10] ALARM 1 OFF DISTANCE
- [11] ALARM 2 ON DISTANCE
- [12] ALARM 2 OFF DISTANCE

Enter the desired distance at which ALARM 1 or 2 is to turn ON. The solid state relay output ALARM 1 or 2, will close whenever the displayed distance equals this value.

Enter the desired distance at which ALARM 1 or 2 is to turn OFF. The solid state relay output ALARM 1 or 2 will open whenever the displayed distance equals this value.

ALARM OFF DISTANCE is usually set to a value which is far enough away from the ALARM ON DISTANCE so that chattering of the alarm will not occur. If delay is set, alarm actuation will be delayed. See section 10, PROGRAM ADJUSTMENT MODE regarding delays and hysteresis. See Figure 7 for pictorial of alarm settings.

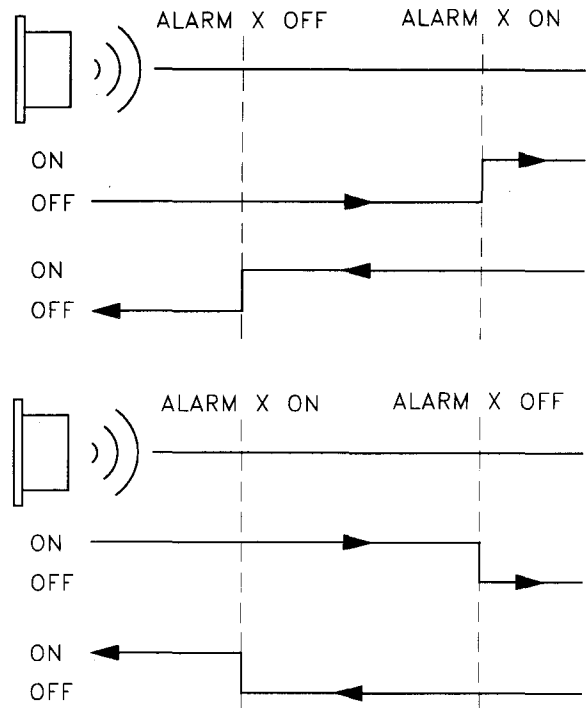

$$\text{display} = \left( \begin{matrix} \text{real} \\ \text{dist.} \end{matrix} - \begin{matrix} \text{dist. for} \\ \text{display=0} \end{matrix} \right) \times \text{RM}$$

Alarm Settings  
Fig. 7

[13] ECHO REJECT DISTANCE Objects that are closer to the sensor than this distance are ignored. The minimum distance between this value and the target is 2 inches (50 millimeters).

[14] DISTANCE FOR DISPLAY=0 The desired distance at which a reading of "0.0" is to occur. This feature functions as an offset. If a value of 2.0 is entered, the DISTANCE display will show 0.0 at a distance of 2.0 inches. See special note below.

*normally set to zero*

[15] READOUT MULTIPLIER The desired scaling value of the DISTANCE display is entered here. Using this feature, a value of 3 would make a target distance of 12.0 inches appear as 36.0. See special note below.

SPECIAL NOTE: DISTANCE FOR DISPLAY=0, and READOUT MULTIPLIER automatically convert the displayed value for DISTANCE, POSITION, DISTANCE FOR MAX OUTPUT, DISTANCE FOR MIN OUTPUT, and ALARM 1 and ALARM 2 ON and OFF.

[16] CLOSED LOOP GAIN The control sensitivity, or how much the control reacts to a change in distance, is adjusted here. This item is available only when the system type selected is 4, FREE LOOP.

[17] INTEGRATOR TIME The responsiveness, or how quickly the control reacts to a change in distance, is adjusted here. This item is available only when the system type selected is 4, FREE LOOP.

[18] P + I = 0 P ONLY = 1 Proportional and Integral, or Proportional only. This item is available only when the system type selected is 4, FREE LOOP.

↗ 1000 second Maximum

[19] **STOP TIME** - This is the number of seconds from the time the user applies the stop signal to when the system is stopped. The stop signal is applied by the user connecting terminals 8 and 9.

[20] **STOPPED** - Light is on when the user connects terminals 8 and 9 and stop time has elapsed. The control is in stop condition, and the output is zero.

**10. PROGRAM ADJUSTMENT MODE** (Only possible when control is in "STOP" mode.)

Pressing and holding both selection arrows for two seconds switches the MISTR into a program adjustment mode. This is indicated by lights 19 and 20 flashing. A third light will be on but not flashing next to the item number which is currently selected. Use the selection arrows to scroll through the item numbers. Hold down both selection arrows again to leave program adjustment mode. The table below designates the items being adjusted when the associated light is on. The underlined settings are the factory settings.

THE DESCRIPTIONS ON THE LABEL INSERT SHOULD BE IGNORED WHILE IN THIS MODE.

LIGHT NUMBER	ITEM
1	Sensor Alignment - Display is blank when an echo is NOT being received and shows distance when an echo IS received.
2	Control Type - Select <u>1</u> for UNWIND, 2 for REWIND, <u>3</u> for RANGER, or 4 for FREE LOOP. If selection is 3 or 4, use the label with RANGER at the top instead of the one with TENSION.
3	Distance Units - Select <u>0</u> for Inches or 1 for Millimeters
4	Output Select - Change this value to 1 when using a -10 to +10 volt output.
5	Output Calibration - Use the ENTER key to select which output point is to be adjusted, 0 or 100 percent. Then, using a meter at terminals 26 and 27 to read the specific values of voltage or current, adjust the output level using the adjustment arrows.
6	MIN and MAX Diameter Detect Hysteresis (for unwinds and rewinds) - Hysteresis allows the target to move a certain distance with no change in output status. It is used to prevent the output from chattering near the set detect distance. Hysteresis is set in distance units using the adjustment arrows. The factory setting is <u>0.1</u>
7	Alarm/Diameter Detect Time Delay - Delays are timed from the moment the target reaches the trigger distance (minus hysteresis if any). If the target moves outside the trigger distance before the delay time is passed, the output will not activate and the delay will be reset as if the target had never reached the trigger distance. The factory setting is <u>.010 seconds</u> .
8	TENSION ON/OFF operation - 0 = momentary, <u>1 = voltage level actuated</u>
9	Setup Number - Select the setup number using the adjustment arrows. Change to the selected setup by holding ENTER for two seconds. Setup Number can also be changed in normal operating mode.

## 11. SETTING JUMPERS

To set the jumpers on the MISTR:

STEP 1 - Pull the terminal blocks from the rear of the MISTR.

STEP 2 - Remove and save the two mounting screws from the front panel.

STEP 3 - Slide the front panel and circuit board assemblies out the front of the enclosure.

STEP 4 - Remove the 3B138-1RPL power amplifier (if present) by removing the two support screws. All jumpers are now accessible.

### JP1 OUTPUT VOLTAGE RANGE SETTINGS

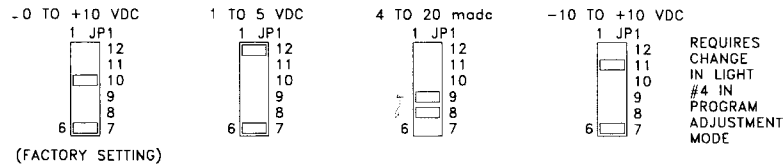

### JP2, JP3, JP4 OPTO-COUPLER SUPPLY VOLTAGE SETTINGS

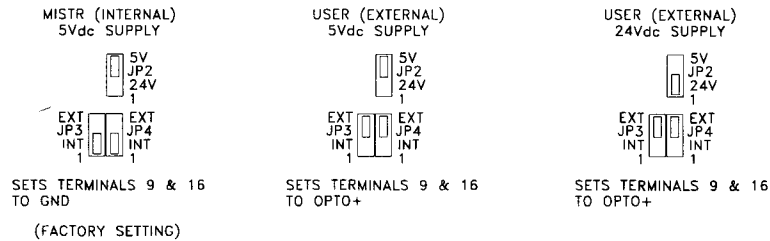

### A.C. POWER SETTING



### RELAY OUTPUT CURRENT SETTINGS

#### ALARM 1 OUTPUT

100mA MAX. AT 30vdc MAX.



ON VOLTAGE = 2.0vdc

(FACTORY SETTING)

4mA MAX. AT 30vdc MAX.



ON VOLTAGE = 0.5vdc

(COMPATIBLE WITH TTL)

#### ALARM 2 OUTPUT

100mA MAX. AT 30vdc MAX.



ON VOLTAGE = 2.0vdc

(FACTORY SETTING)

4mA MAX. AT 30vdc MAX.



ON VOLTAGE = 0.5vdc

(COMPATIBLE WITH TTL)

#### TENSION ON/OFF OUTPUT

100mA MAX. AT 30vdc MAX.



ON VOLTAGE = 2.0vdc

(FACTORY SETTING)

4mA MAX. AT 30vdc MAX.



ON VOLTAGE = 0.5vdc

(COMPATIBLE WITH TTL)

### Jumper Settings

Fig.8

STEP 5 - Reinstall power amplifier if removed. Replace main p.c.board in the third slot from bottom. Replace the two front panel screws.

STEP 6 - Replace terminal blocks.

## 12. REMOTE CONTROL WIRING

Wiring terminals are provided which allow the user to signal a stop, an emergency stop, adjust tension, change setups, turn tension on or off, get an indication of output %, alarm status and tension on/off at a remote location. These terminals are isolated and setable for a 24 volt or a TTL level voltage using an internal +5 volt supply or the users +5 or +24 volt supply. For any configuration of the inputs, zero volts applied to an input terminal causes that terminal's function to become active. Local front panel adjustments are ignored while corresponding remote adjustments are being made. As an example: TENSION SETPOINT % cannot be changed using the adjustment arrows while terminals 11 or 12 are connected to zero volts because that would mean that tension is being adjusted at another location.

**RUN/STOP** - Connect this terminal to zero volts when stopping to compensate for inertia, or to change setups or operating modes.

**GND or OPTO+** - This terminal is factory set to GND. GrouND is what the MISTR thinks is zero volts. This terminal may be set to OPTO+, and used to connect the user's dc voltage to isolate the user's ground from the MISTR's GrouND. The user then uses his ground as zero volts, instead of the MISTR's GND. See SETTING JUMPERS, prior section.

**E-STOP** - The MISTR is shipped from the factory with a wire jumper between this terminal and GND. The jumper can be removed and a normally closed switch or several normally closed switches connected in series can be wired in its place to create an emergency stop circuit. The output will go to maximum on unwinds, and to 0 on rewinds, and free loops, when the circuit is broken. Once this happens the emergency stop circuit must be re-established and the RUN/STOP terminal must be connected to zero volts momentarily to be able to run again. The STOPPED light will flash when an E-STOP has been initiated. E-STOP is not functional in Ranger Mode. If the GND/OPTO+ terminal is set to OPTO+ , the factory installed wire jumper must be removed and the E-STOP terminal connected to zero volts whether directly or through the E-STOP wiring.

**REMOTE TENSION/DISTANCE ADJUSTMENT** - Connecting terminal 11 to 0 volts will cause TENSION SETPOINT % or POSITION (command distance) to increase.

**REMOTE SETUP SELECT** - The following table defines the function of the setup select terminals. The letter "V" implies that the terminal is at the selected supply voltage, 5 or 24 volts.

Setup	Terminal 15	Terminal 14	Terminal 13
Select from Front Panel	V	V	V
1	V	V	0 volts
2	V	0 volts	V
3	V	0 volts	0 volts
4	0 volts	V	V
5	0 volts	V	0 volts
6	0 volts	0 volts	V
Select from Front Panel	0 volts	0 volts	0 volts

**TENSION ON/OFF** This terminal is for connection of an external tension on/off switch so that tension or output can be turned on and off remotely. Connecting terminal 17 to 0 volts will turn tension off. Disconnecting it from 0 volts will turn tension on again. Front panel TENSION ON/OFF operation is disabled while terminal 17 is connected to 0 volts, meaning tension is turned off at another location. Tension must be turned on at the remote location for front panel TENSION ON/OFF operation to resume. NOTE: If JP3 and JP4 are set to internal 5 volt supply (the factory setting), terminal 16 will be at 0 volts and terminal 17 could be connected there (by the switch) for 0 volts. An output is provided at terminals 22 and 23 to indicate the state of tension.

This input can also be made to function with a push-button switch so that connecting terminal 17 to 0 volts momentarily will turn tension off, if it was on, and on if it was off. See PROGRAM ADJUSTMENT MODE, section 10.

**ALARM 1, ALARM 2** - Both alarm outputs function identically but are independent. Each has an open collector output which can switch up to 100 ma at its 24 volt setting and 4 ma at its 5 volt setting. An output is considered to be on when the MISTR connects the two terminals associated with it together. For example: When ALARM 1 is turned on, terminals 18 and 19 are connected together. When the system type is UNWIND or REWIND, ALARM 1 turns on when the target reaches the MIN DIAMETER DETECT distance. ALARM 2 turns on when the target reaches the MAX DIAMETER DETECT distance. When the system type is set to RANGER or FREE LOOP there are four distance settings ALARM 1 ON DISTANCE, ALARM 1 OFF DISTANCE, ALARM 2 ON DISTANCE, and ALARM 2 OFF DISTANCE which determine at what target position each alarm will turn on or off.

**TENSION ON/OFF output** - This is an output which has the same electrical capabilities as the ALARM outputs. The MISTR connects terminals 22 and 23 when TENSION is on and disconnects them when tension is off.

**0-1mA OUTPUT** - A 1 milliamp DC meter may be connected to terminals 24 and 25 to get a remote indication of % OUTPUT.

### 13. INSTALLATION OF 3B138-1RPL 24/90 VOLT POWER AMPLIFIER

PACKING LIST	Qty.	Description
	1	3B138-1RPL 24/90 volt Power Amplifier
	1	1 1/2" Standoff
	3	1 3/4" Standoffs
	2	Mounting Screws for Standoff
	1	Mounting Screw for Angle Bracket
	1	10 Conductor Ribbon Cable Assy.
	1	Terminal Block

STEP 1 - For front panel mounted version, pull the terminal blocks from the rear of the MISTR.

STEP 2 - Remove and save the two mounting screws from the front panel.

STEP 3 - Slide the front panel and circuit board assemblies out the front of the enclosure.

STEP 4 - For all MISTR versions, insure JP1 on the main printed circuit board is set to 0 to +10vdc output.  
See section 11, SETTING JUMPERS

STEP 5 - Set jumpers on the power amplifier board as shown below in figure 9. The voltage setting, JP1 is for 24 or 90 volt clutches/brakes. The current range setting JP1, is for different current rating clutches & brakes. See the catalog for the current rating of the clutch or brake you are using, and set JP2 to the appropriate range.

VOLTAGE SETTINGS

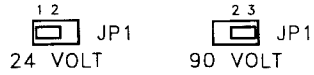

CURRENT RANGE SETTINGS

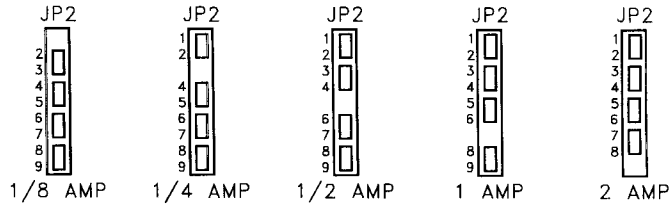

Power Amp Jumper Settings  
Fig. 9

STEP 6 - Assemble Power Amplifier per figures 10 or 11.

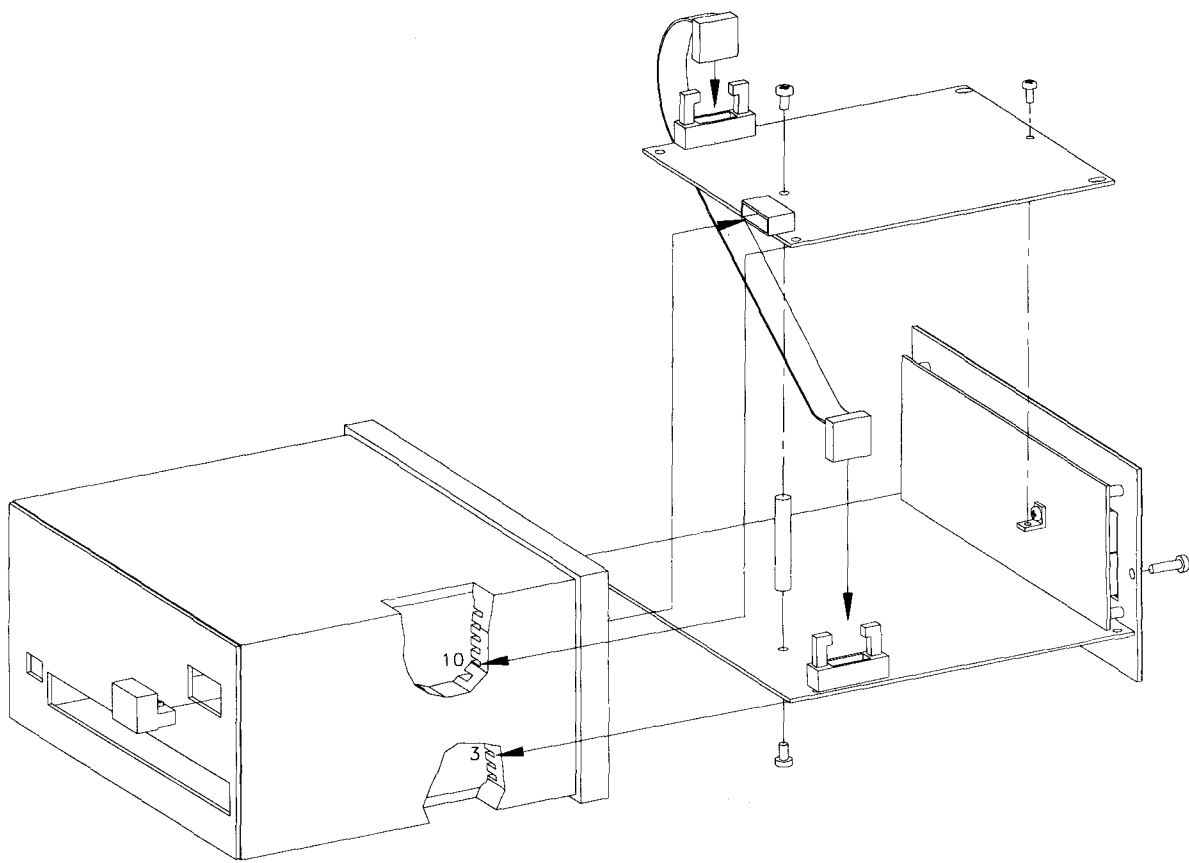

Power Amplifier in enclosure model  
Fig. 10

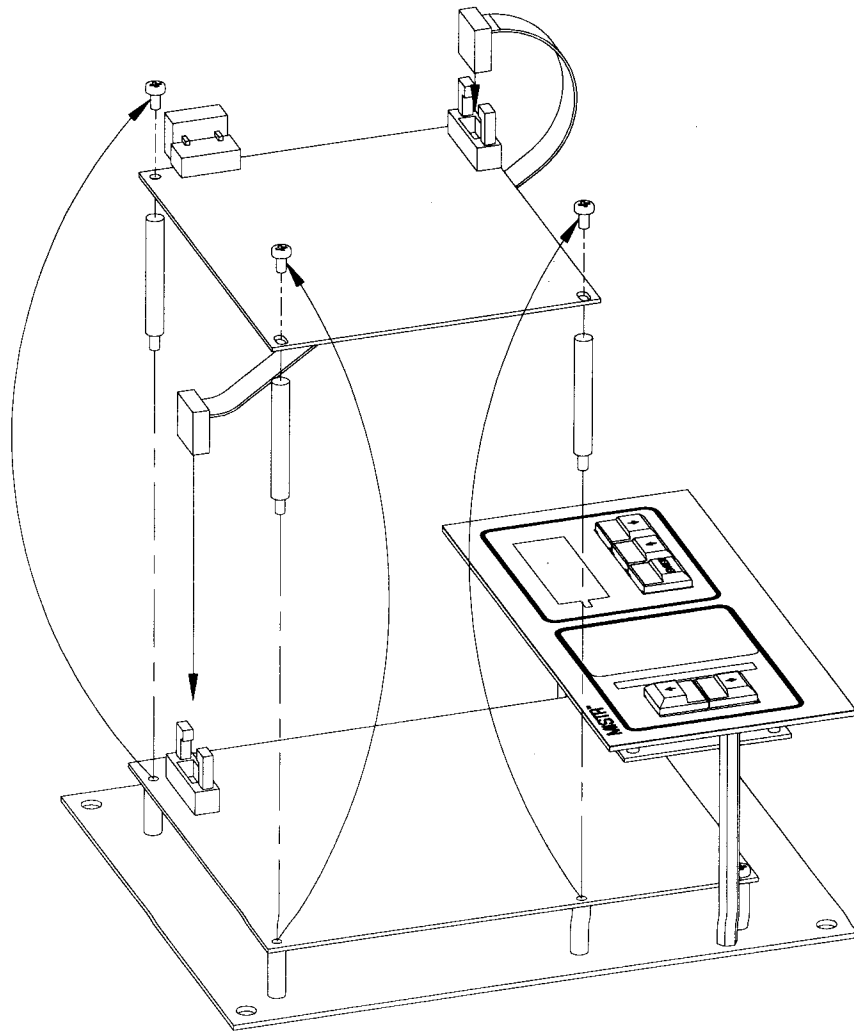

Power Amplifier in back panel model  
Fig. 11

STEP 7 - On the rear of the enclosure model MISTR, remove the label area below terminal 101-104.

STEP 8 - Connect clutch & brake wiring to terminals 101 and 102, and connect appropriate ac voltage to terminals 103 and 104.

#### 14. ERROR CODES

- E00** System not stopped.
- E01** External setup active, setup not changable from keypad.
- E02** Copy "TO" setup is secure, cannot copy to it.
- E03** Setup is secured, no changes allowed to this value.

#### 15. RESET PROCEDURE

The memory can be reset to the factory default settings. All prior data will be lost. To reset, hold down the ENTER key and both ADJUSTMENT ARROW keys while turning power on.

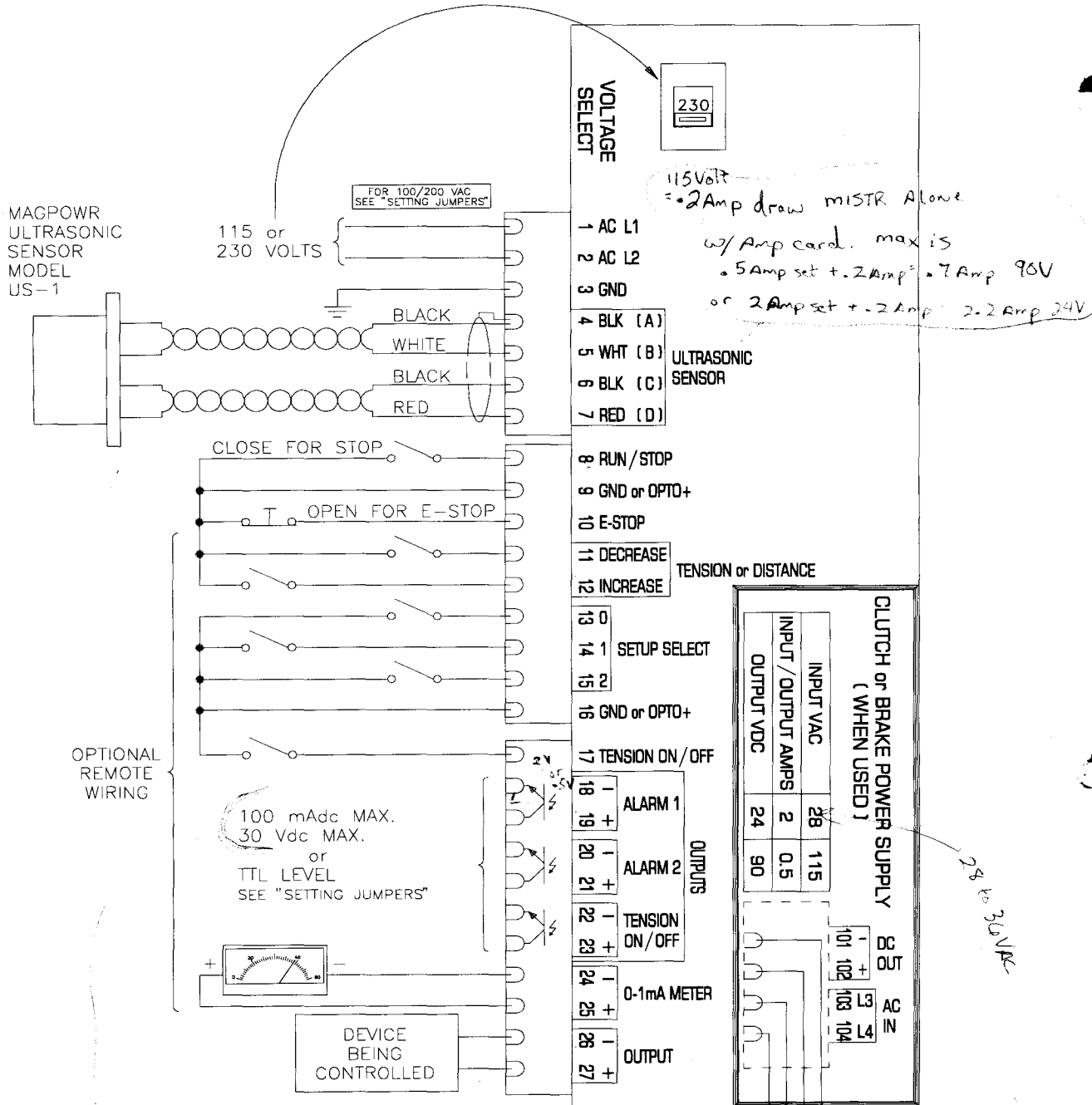

- CAUTION:
- 1) SET VOLTAGE SELECT SWITCH BEFORE APPLYING POWER.
  - 2) ALL JUMPERS MUST BE SET BEFORE APPLYING POWER.

Alarn's

850A124-1  
August 1995

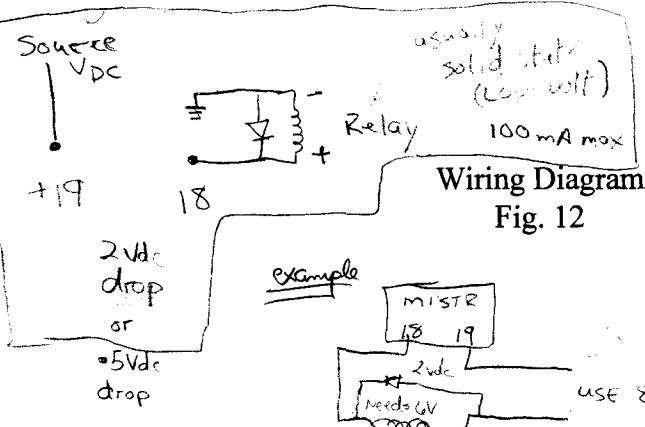

Wiring Diagram  
Fig. 12

115 VAC  
OR  
28 VAC  
to 30VAC

CLUTCH  
OR  
BRAKE