



A. Mascess
International
Company

Magnetic Power Systems, Inc.

1626 Manufacturers Drive. Fenton, MO 63026

Tel: 636.343.5550 | Fax: 636.326.0608 | magpowr@magpowr.com

INSTRUCTION MANUAL

MODEL PS90

90 VDC POWER SUPPLY

1.0 Introduction

The MAGPOWR Model PS90 is an isolated controllable current regulator for 90 vdc magnetic particle clutches and brakes. The PS90 also provides a small amount of reverse current to minimize the drag torque of the clutch / brake.

The Model PS90 has four jumper selectable current ranges. Maximum outputs for the individual ranges are 0.125, 0.25, 0.5 and 1.0 adc. The appropriate range is determined by the current rating of the clutch or brake to be controlled. For best torque control resolution, the lowest current range providing sufficient current for maximum operating torque should be selected.

The PS90 accepts either a remote adjustment potentiometer, or a 0 to 10 vdc analog control signal.

Connections are provided for an external 1 madc current meter. The meter display will indicate output current as a percentage of the output range selected.

The control circuits are electrically isolated from the power circuits.

2.0 Installation

The PS90 is intended for installation on a vertical panel with a DIN 35 rail, with the wiring terminals facing down. Figure 1 shows the enclosure dimensions.

Wiring to and from the PS90 must be done with double or reinforced insulation or protective screening which provides protective separation. All wiring should comply with the essential requirements of the appropriate standard(s) and is the responsibility of the installer.

Route AC power away from control signal wiring. Connect shields of shielded cable to the terminals indicated as "SHIELD". Maximum shield length and maximum length of wires outside of the shield is 3 in. (75 mm).

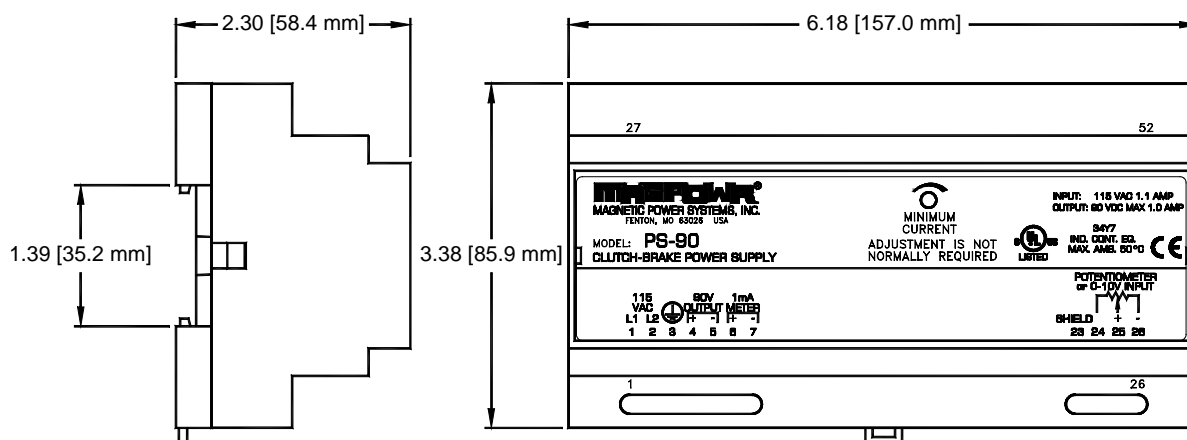

Figure 1
Enclosure Dimensions

3.0 Setup

Remove the enclosure top by inserting a flat blade screwdriver under the retaining tabs in the base (See figure 2). Set the JP1 current range selection jumpers to the range appropriate for the clutch / brake connected to the PS90 (See figure 3 for current range settings). The factory setting is 1/8 amp range. Replace the enclosure top.

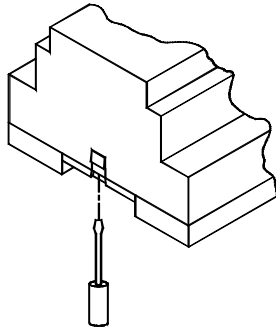

Figure 2

Enclosure Top Removal

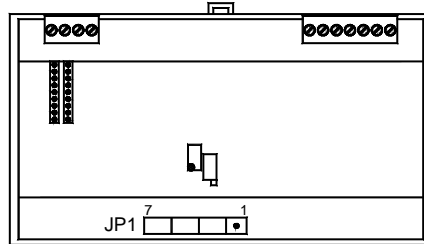

Figure 3

JP1 Current Range Settings

JP1 CURENT RANGE							
AMP	7	6	5	4	3	2	1
1/8	•	•	•	•	•	•	•
1/4	•	•	•	•	•	•	•
1/2	•	•	•	•	•	•	•
1	•	•	•	•	•	•	•

4.0 Electrical Connections

Figure 4 shows the connections that are required for the basic system. They are:

- 115 vac power
- 90 vdc output for clutch / brake
- 1 to 10 kohm Potentiometer

Route AC power away from control wiring. The clutch / brake wires and the remote meter wires should be twisted pair. Run the signal input wiring in shielded cable. Connect the shield to the provided terminal marked "SHIELD". The maximum shield length and maximum length of wires outside of the shield is 3 in. (75 mm).

When using a 0-10 vdc input instead of a potentiometer, connect the negative of the input to terminal 26 and the positive of the input to terminal 25.

The 90 vdc output and the remote meter output are not isolated from the AC line and must not be ground referenced. The potentiometer input is isolated and may be ground referenced.

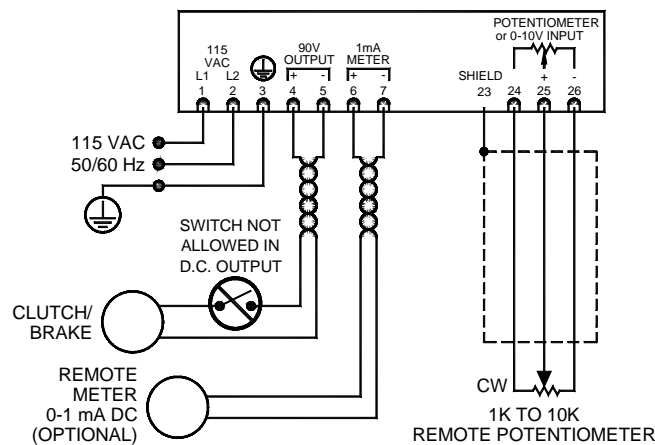

Figure 4

Electrical Connections for PS90

5.0 Maintenance

The only maintenance that may be required on the PS90 is fuse replacement. Replacement of the fuse(s) requires first removing ac power, then opening the enclosure. The enclosure must be re-installed to maintain the IP rating. The enclosure may be opened by inserting a flat blade screwdriver under the retaining tabs in the base (See figure 2).

6.0 Troubleshooting

Symptom	Possible Cause	Solution or Diagnostic
No clutch / brake output.	No AC power.	Verify incoming power is correct voltage and frequency.
	Fuses blown.	Clutch / brake wires shorted together or shorted to ground.
	Clutch / brake wires open circuit.	Disconnect clutch / brake wires at the PS90 and check for proper clutch / brake resistance between the wires.
	Remote potentiometer or external power supply not wired correctly, or shorted together.	Voltage between terminal 24 and 26 should be 10 vdc. Voltage between terminal 25 and 26 should vary from 0 to 10 vdc as the potentiometer or external 0 to 10 vdc power supply is moved through its range of travel.
Remote meter not working.	Incorrect type of meter.	Meter should be a current meter with 1 ma full scale and no more than 3 kohm resistance.
	Meter wires shorted or open.	Disconnect meter wiring at the PS90 and check for proper meter resistance between the wires.

7.0 Options

The PS90 is factory adjusted to provide full reverse current with 0 vdc input. If some other current is desired with 0 vdc input or the minimum remote potentiometer setting, the minimum current potentiometer may be adjusted by cutting out the hole shown on the label and then using a trimpot adjustment tool. Modifying this setting will cause the clutch / brake drag torque to be higher than expected and is not recommended.

8.0 Specifications

Supply Voltage: 115 vac, +/- 10%, 50/60 Hz, 1.1 amp maximum, sinusoidal
Fuses: F1, F2 1.6 amp, Littelfuse Part No. 21601.6, or
Wickmann Part No. 19194-053-FS

Enclosure: IP20
Climatic Class: 3K3 (EN60721)
Temperature Range:
 Operating: 0° C to 50° C
 Storage: -30° C to 80° C
Relative Humidity: 5% to 85%
Pollution Degree: 2 (IEC664-1)
Altitude: 0 to 2000 m

Compatible Residual Current
 Device Types: A or B (IEC755)
Worst Case Fault Current: 1.6 amp

Inputs:

Signal Potentiometer: 1 to 10 kohm, ¼ watt minimum
or
Voltage: 0 to 10 vdc, 100 kohm input impedance

Outputs:

Clutch / Brake

Voltage: -3 to 90 vdc, full wave, phase controlled
Current: Adjustable in four ranges:
-0.004 to 0.125 madc
-0.008 to 0.25 madc
-0.016 to 0.5 madc
-0.032 to 1.0 madc

Regulation: < 1% of range
Current Drift: 0.024 %/° C

Meter Signal: 0 to 1 madc, +/-2% into 3 kohm maximum

Potentiometer Supply Voltage: 10 vdc +/-2%, 10 madc maximum